

- 280 W AC-DC / 3" X 5.3" FOOTPRINT
- AVAILABLE MODELS: 12V – 56V
- UP TO 90% EFFICIENCY
- HIGH POWER DENSITY: OVER 13 W / in<sup>3</sup>
- ALL OUTPUTS MAY BE PARALLELED
- REMOTE ON / OFF
- 5V STANDBY OUTPUT (1A)
- 12V AUX OUTPUT (1A)
- UNIVERSAL AC INPUT
- ACTIVE PFC (90 – 264 VAC)
- ACTIVE CURRENT SHARING FOR N, N+1
- ACTIVE INRUSH CURRENT PROTECTION
- RoHS COMPLIANT



**POWER SUPPLY DESIGN LEADER**

N2Power™ leads the power density race with its high efficiency XL280 Series AC-DC power supplies. Our advanced technology yields a very small footprint, reduces wasted power, and

**TWICE THE POWER IN HALF THE SPACE**

offers the highest power density in its class. This efficient design means reduced energy costs, a greater return on your investment, greater reliability and longer product life.

**UNMATCHED POWER DENSITY**

With an overall height of 1.35" and a 3" x 5.3" footprint, the XL280 Series boasts a power density over 13 watts per cubic inch. It is ideally suited for OEMs using the industry standard 1U chassis.

**HIGH EFFICIENCY IN A SMALL PACKAGE**

The XL280 Series provides up to 90% efficiency. Our unique design reduces energy consumption and generates less wasted heat. It requires little forced air cooling, decreases AC power consumption, increases reliability and economy of operation. Comparisons of efficiencies show that our supplies can reduce losses up to 50%.

**COMPLETE PROTECTION**

The main output is enabled whenever all of the required startup conditions are met, and is shut down upon command, loss of input power or whenever excessive loads or temperatures are sensed. When AC input power is lost it provides the host system with advanced warning of an impending shutdown.

**Typical Mechanical Drawing:**

Inches (millimeters), refer to XL280 Product Specification for complete information.

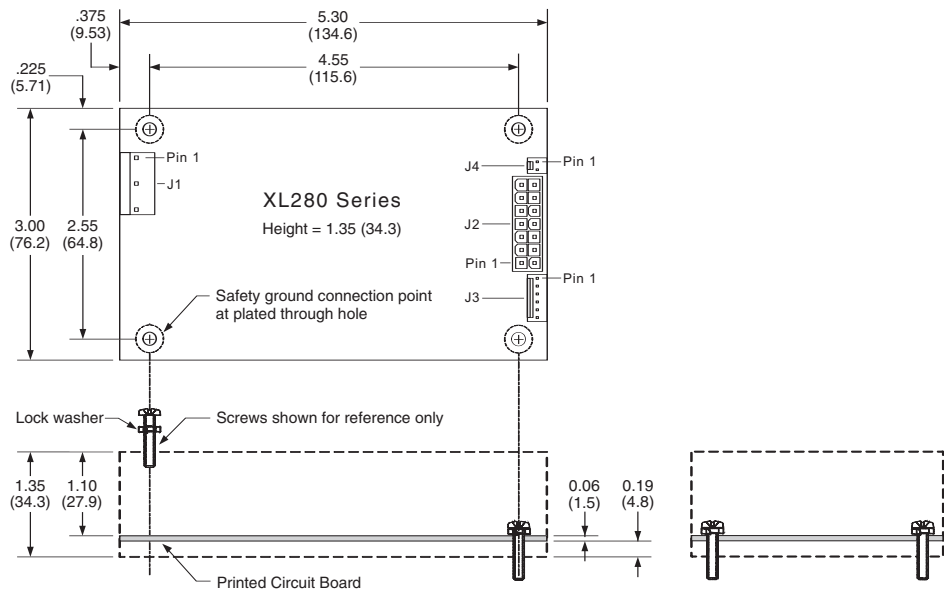

MODEL	PART NUMBER	OUTPUT	VOLTAGE	REGULATION (%)	MAXIMUM CURRENT (A)	RIPPLE & NOISE (P-P)
XL280-12 XL280-12 CS	400082-01-2 400081-01-4	V1	12	±3	23.3	120 mV
		V2	12	±5	5.0	120 mV
		V3	12	±5	1.0	120 mV
		V4	5sb	±5	1.0	50 mV
XL280-24 XL280-24 CS	400082-02-0 400081-02-2	V1	24	±3	11.7	240 mV
		V2	12	±5	5.0	120 mV
		V3	12	±5	1.0	120 mV
		V4	5sb	±5	1.0	50 mV
XL280-48 XL280-48 CS	400082-03-4 400081-03-0	V1	48	±3	5.8	480 mV
		V2	12	±5	5.0	120 mV
		V3	12	±5	1.0	120 mV
		V4	5sb	±5	1.0	50 mV
XL280-54 XL280-54 CS	400082-04-6 400081-04-8	V1	54	±3	5.2	540 mV
		V2	12	±5	5.0	120 mV
		V3	12	±5	1.0	120 mV
		V4	5sb	±5	1.0	50 mV
XL280-56 XL280-56 CS	400082-05-3 400081-05-5	V1	56	±3	5.0	560 mV
		V2	12	±5	5.0	120 mV
		V3	12	±5	1.0	120 mV
		V4	5sb	±5	1.0	50 mV

CS = Current Sharing

INPUT SPECIFICATIONS	
Nominal Input Voltage:	100 – 240 VAC
Tested Input Limits:	90 – 264 VAC
Input Frequency Range:	47 – 63 Hz
Input Current:	4.3 A @ 100 VAC
Input Protection:	6.3 A fuse
Safety Isolation:	3000 VAC input to output 1500 VAC input to ground
Inrush Current:	14 A @ 240 VAC†
Power Factor Correction:	Active PFC circuitry, meets or exceeds EN61000-3-2
Leakage Current:	0.75mA @ 240 VAC / 60 Hz†

OUTPUT SPECIFICATIONS	
Total Output:	280 W
Hold-up Time:	Minimum 22 mS
Efficiency:	Up to 90%†
Minimum Load:	No load†
Over / Under Shoot:	Maximum 10% at turn-on
Output Isolation:	For POE†
PROTECTION	
Overvoltage Protection:	V1 (latches off)
Overpower Protection:	Protected / Auto Recovery
Short Circuit Protection:	Auto recovery of all outputs
Thermal Shutdown:	Auto recovery protection against over temperature conditions

OPERATING SPECIFICATIONS	
Operating Temperature:	-25°C to +50°C
Temperature Derating:	2.5% / degree 50°C to 70°C
Storage Temperature:	-40°C to +85°C
Forced Air Cooling:	10 CFM minimum†
Convection Cooling:	See Specification <sup>Δ</sup>
MTBF:	> 160,000 hours calculated†
SIGNALS	
Remote Sense:	V1 and Return
Current Sharing:	V1 using active circuitry
Passive Redundancy:	V2 and V3 outputs may be wire OR'ed
Power Good (PG) Output:	High - true CMOS logic
Remote Enable Input:	Low-true input enables V1, V2, V3 output

† See Product Specification      Δ Some Models

**COMPLIANCE:**

**USA/Canada:**  
UL60950-1:2007 (2nd Edition) / C22.2 No. 60950-1-07 (Bi-National Standard) Safety of Information Technology Equipment

**Europe:**  
Directive 2006/95/EC - "Low Voltage (Safety) Directive"

IEC 60950-1:2005 (2nd Edition) Safety of Information Technology Equipment. (CB Report)

Directive 2004/108/EC "Electromagnetic Compatibility (EMC) Directive"

EN61204-3:2001 Stabilized Power Supplies, d.c. Outputs EMC Standards Specification  
EN61204-3:2001 is a product family EMC standard referencing the following standards:  
EN61000-3-3 Limits of Voltage Fluctuations & Flicker  
EN61000-3-2 Harmonic Current Emissions (Power Factor Correction)  
EN61000-4-3 Radiated Radio Frequency.

Electromagnetic Field Immunity  
EN61000-4-4 Fast Transient / Burst Immunity  
EN61000-4-5 Surge Immunity  
EN61000-4-6 Immunity to Conducted Disturbances  
EN61000-4-11 Voltage Dips, Short Interrupts & Voltage Variations

Directive 2002/95/EC - "Restriction of Hazardous Substances (RoHS)"  
Safety Approvals:  
UL, cUL, CB Certificate, CB Report. CE Mark

