



Product Specification

XL260-2ATX, -4ATX

260-Watt AC to DC

Power Supplies

704873 Rev. A1

Notices

N2Power is a wholly owned subsidiary of Qualstar Corporation.

N2Power and the *N2Power* logo are registered trademarks of Qualstar Corporation.

Copyright® 2009-2012 by Qualstar Corporation — All Rights Reserved

For warranty information refer to www.n2power.com

Information contained in this document is copyrighted by Qualstar Corporation and is intended for use by customers and prospective customers to evaluate and integrate our power supplies. Customers and prospective customers may reproduce this document as needed for these purposes. Reproduction in whole or in part for any other purpose or by any other party is prohibited without prior written permission from Qualstar Corporation.

Every effort has been made to keep the information contained in this document current and accurate as of the date of publication or revision. However, no guarantee is given or implied that the document is error-free or that it is accurate with regard to any specification.

N2Power reserves the right to modify the design or specification without notice. This specification may not be construed as a contractual obligation except as specifically agreed to by *N2Power* in writing at the time of order.

Some *N2Power* products are covered by U.S. Patent 6,163,139.

For information about this product specification, please write or call *N2Power* at:

N2Power

A Qualstar Company
3990-B Heritage Oak Court
Simi Valley CA 93063

FAX: (805) 583-7749
Phone: (805) 583-7744

E-Mail: sales@n2power.com
www.n2power.com

Revision History

Date	Revision	Description	By
09/07/2011	A	Initial Release	DWK
05/25/2010	6	Added XL260-4ATX Model	RAN
10/09/2009	5	Added warranty link & RoHS statement, new sales extension, colorized Logos, removed header P/Ns	RAN
06/10/2009	4	Added Figure 1-1, change 20 CFM to 10, changed weight to .91 lbs.	RAN
05/13/2009	3	Added leakage current and power factor	RAN
03/24/2009	2	Updated the Environmental Table 4-1 with Mil-Spec Numbers, Specified MTBF at 25°C	RAN
02/05/2009	1	Initial Draft	DWK

Table of Contents

1.	Introduction.....	1-1
1.1	Introduction	1-1
1.2	Agency Compliance	1-2
2.	AC Input.....	2-1
2.1	Input Line Requirements	2-1
2.2	Input Over Current Protection.....	2-1
2.3	Inrush Current Limiting	2-1
2.4	Low Input Voltage.....	2-1
2.5	Leakage Current	2-2
2.6	Power-Factor	2-2
3.	DC Outputs.....	3-1
3.1	Output Voltage Regulation.....	3-1
3.2	No Load Operation	3-1
3.3	Output Current and Power.....	3-1
3.4	Output Ripple and Noise	3-3
3.5	Remote Sensing	3-4
3.6	Output Protection.....	3-4
3.7	Output Rise Time	3-5
3.8	Output Overshoot.....	3-5
3.9	Output Transients.....	3-5
3.10	Closed Loop Stability	3-5
3.11	Capacitive Load.....	3-6
3.12	Efficiency	3-6
4.	General Specifications	4-1
4.1	Environmental.....	4-1
4.2	Component Derating.....	4-1
4.3	Mean Time between Failures.....	4-1
4.4	Labeling/Marking.....	4-2
4.5	Mounting.....	4-2
4.6	Physical Dimensions	4-3
4.7	Weight.....	4-3
4.8	Mating Connectors	4-4
4.9	Output Grounding.....	4-6
4.10	Signal Pin Definitions.....	4-6
5.	Timing and Control.....	5-1
5.1	Power Supply Timing.....	5-1
5.2	Power Good Signal	5-1
5.3	PS_ON Input	5-2
5.4	Hold-Up Time	5-2
6.	Ordering Information.....	6-1

1.

Introduction

1.1 Introduction

This specification defines the design and performance characteristics of the XL260-2ATX and XL260-4ATX open frame, single-phase (3-wire), universal input, power-factor corrected, multiple output, 260-watt switch mode power supplies. It includes information regarding its installation, cooling requirements, connector configurations, electrical and signal specifications, and environmental ranges for storage and operation of the power supply. The XL260-2ATX and XL260-4ATX are multiple-output supplies with a 5VSB at 1A standby supply that remains on, even when the main outputs are shut-off remotely.



Figure 1-1 XL260-2ATX

1.2 Agency Compliance

Safety	Complies with Standard	Remarks
United States	UL 60950-1 (2007) Second Edition (Information Technology Equipment)	Leakage Current – see table 2-2 Hi-pot – 2121vdc for 1 second
Canada	CSA 22.2: 60950-1	
EU Council	2006/95/EC	Low Voltage Directive
International	IEC 60950-1 (2005) Second Edition	
EMC	Complies with Standard	Remarks
United States	FCC part 15, subpart B	Conducted emissions Limits per CISPR 22 Class B Tested to ANSI C63.4: 2003
EU Council	2004/108/EC	EMC Directive
International	EN 61204-3 (refers to the following) EN 55022 Class B EN 55024 (refers to the following) EN 61000-3-2 Class D EN 61000-3-3 EN 61000-4-3 EN 61000-4-4 EN 61000-4-5 EN 61000-4-6 EN 61000-4-11	Low Voltage Power Supplies – DC Output Conducted emissions Limits per CISPR 22 Class B Immunity Harmonic Current Emissions (Power Factor Correction – PFC) Voltage Fluctuations & Flicker Radiated Susceptibility Fast Transient/Burst Immunity Power Mains Surge Immunity RF Immunity Voltage Dips, Short Interruptions
Reduction of Hazardous Substances (RoHS)	Complies with Standard	Remarks
EU Council	2002/95/EC	RoHS Directive
Marks of Conformance		
United States & Canada		
Europe		
EU Council		
RoHS		

Table 1-1 Agency Compliance

2.1 Input Line Requirements

The XL260-2ATX and XL260-4ATX are capable of supplying full rated power in continuous operation throughout the specified ranges of voltages and frequencies listed in Table 2-1. The power supply will automatically recover from AC power loss and is capable of starting under maximum load at the minimum AC input voltage described below.

Parameter	Minimum	Nominal	Maximum
RMS Input Voltage	90 VAC	100-240 VAC	264 VAC
RMS Input Current	–	–	3.5 A @ 100 V
RMS Input Current	–	–	1.6 A @ 240 V
Input Frequency	47 Hz	50/60 Hz	63 Hz

Table 2-1 AC Input Parameters

2.2 Input Over Current Protection

The XL260-2ATX and XL260-4ATX incorporate a primary AC line fuse for input over current protection to prevent damage to the power supply and meet product safety requirements as outlined in Section 1.2.

2.3 Inrush Current Limiting

The cold-start inrush current at a 90-degree phase angle (the AC switch is closed at the peak of the AC waveform) is limited to 13-amps peak at 240 VAC input voltage and 6.5-amps peak at 120 VAC @ 25C.

Repetitive ON/OFF cycling of the AC input voltage should not damage the power supply or cause the input fuse to fail as long as the power remains off for two or more seconds when the outputs are unloaded (less depending upon the output loads).

2.4 Low Input Voltage

The application of an input voltage below the minimums specified in Table 2-1 shall not cause damage to the power supply.

2.5 Leakage Current

The leakage current from AC line or AC Neutral inputs to Protective Earth varies linearly with the input voltage and frequency (see operating column of Table 2-2). The leakage currents of multiple power supplies are additive. Consult the appropriate electrical safety specification for the maximum leakage current permitted in your product. The leakage current will always go to zero when a DPDT switch simultaneously disconnects both the line and neutral circuits.

Line Voltage Frequency	Operating
115VAC, 60Hz	0.75 mA
240VAC, 60Hz	1.50 mA
240VAC, 50Hz	1.25 mA

Table 2-2 Leakage Current – Single XL260-2ATX and XL260-4ATX

2.6 Power-Factor

The input power-factor exceeds 0.98 from 100VAC to 240VAC at full-load.

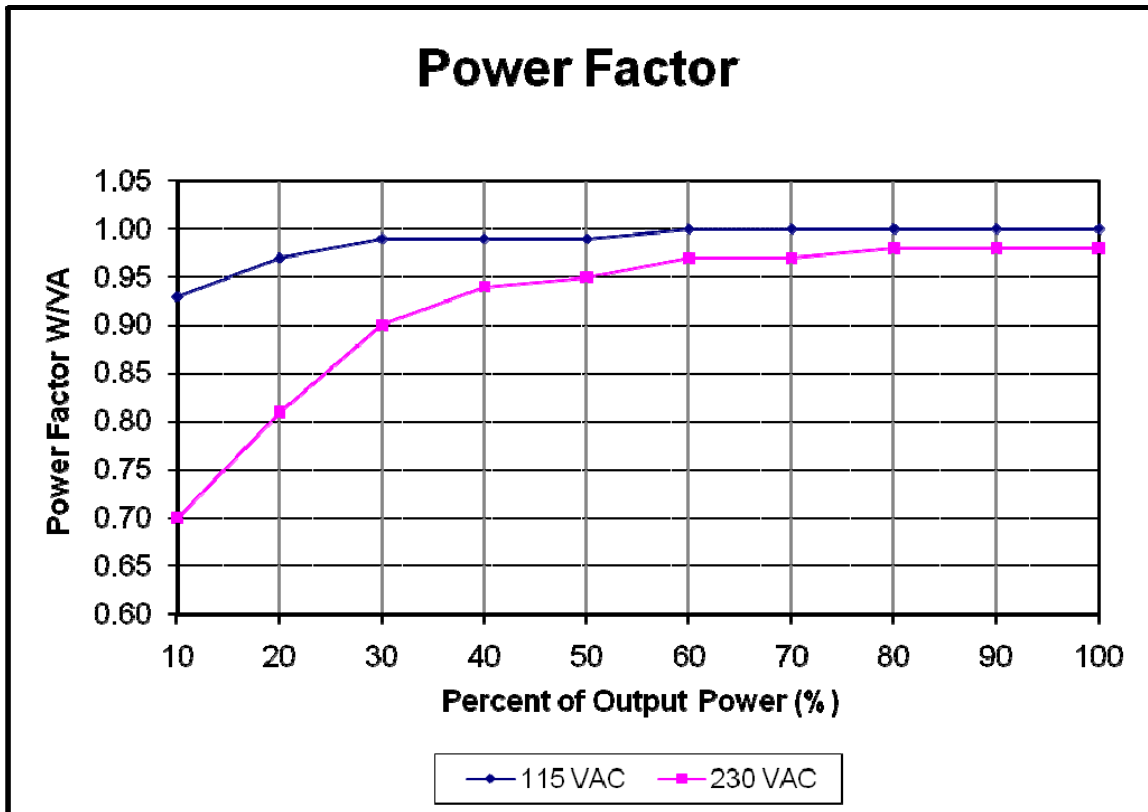

Figure 2-1 Typical Power Factor

3.

DC Outputs

3.1 Output Voltage Regulation

The DC output voltages shall remain within the Minimum and Maximum limits of Table 3-1 when measured at J2 connector under all specified line, load and environmental conditions contained herein.

Output	Voltage	Regulation	Minimum (VDC)	Nominal (VDC)	Maximum (VDC)	Remote Sense
-2ATX V1	+24V	±4%	23.04	24.00	24.96	
-4ATX V1	+48V	±4%	46.08	48.00	49.92	
V2	+5V	±4%	4.85	5.05	5.25	+V2 only
V3	+12V	±5%	11.40	12.00	12.60	
V4	+12V	±5%	11.40	12.00	12.60	
V5	+5V _{standby}	±5%	4.75	5.00	5.25	

Table 3-1 Output Voltage Specifications

3.2 No Load Operation

The power supply will operate with reduced output voltage regulation of +/-5% on V1 and V2 with all outputs unloaded. This no load condition will not damage the supply or cause a hazardous condition. The power supply will remain stable and operate normally after application of the minimum loads specified in Table 3-2.

CAUTION

Remove AC power prior to attaching or removing secondary loads.

3.3 Output Current and Power

The maximum available output power is always a function of the cooling air's flow and temperature. The total available output power is reduced with unrestricted natural convection cooling at an ambient temperature of 50°C or less (see Sections 3.3.1).

3.3.1 Output Power and Cooling

The maximum combined output power is limited to 260-watts with 10 CFM of forced air-cooling at no more than 50°C impinging at either end (3" / 76.2mm dimension). The 5V_{standby} output is limited to 5-watts under the same conditions. Under these cooling conditions, the individual outputs have the following limitations:

Output	Rated Voltage	Minimum Load	Maximum Load	Maximum Watts
-2ATX V1	24 V	0.0 A	6.0 A*	144.0
-4ATX V1	48 V	0.0 A	3.0 A*	144.0
V2	+5 V	1.0 A	10.0 A	50.0
V3	+12 V	0.0 A	5.0 A	60.0
V4	+12 V	0.0 A	0.7 A	8.4
V5	+5 V _{standby}	0.0 A	1.0 A	5.0

* Also pulse rated, see Section 3.3.3 below

Table 3-2 Individual Min/Max Load Currents

3.3.2 Natural Convection Cooling

With unrestricted natural convection cooling, the maximum combined output power of V1 through V4 is reduced from 260-watts to 100-watts while the +5V_{standby} output is limited to 0.5A for a total of 102.5-watts.

3.3.3 24V/48V Output Pulse Current

In addition to its continuous rating of 6A/3A (144-watts), the +24V/48V output can provide a peak output of 15A/7.5A (360-watts) for 0.5-second period provided the load pulse is not repeated for at least 20-seconds.

3.3.4 High Temperature Derating

The supply can be operated at elevated temperatures by derating the total average output power by 2.5% per degree-centigrade from 50°C to 70°C (see Figure 3-1). Operating within this elevated temperature range still requires cooling air flow as described in Section 3.3.1.

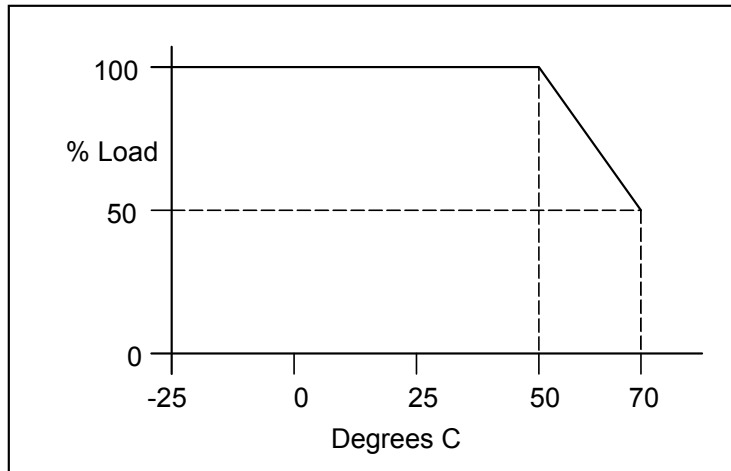

Figure 3-1 Output Power vs. Ambient Temperature Envelope

3.4 Output Ripple and Noise

Output ripple voltage and noise are defined as periodic or random signals over a frequency band of 10 Hz to 20 MHz. Measurements are to be made with an oscilloscope with at least 20 MHz bandwidth. The measured output must be bypassed at the connector with a 0.1 μ F ceramic disk capacitor and a 10 μ F tantalum capacitor to simulate system loading (see Figure 3-2). Ripple and noise shall not exceed the limits specified in Table 3-3 under any condition of line voltage and frequency specified in Section 2.1 and DC loading specified in Table 3-2.

Output	Voltage	Maximum Ripple+Noise (peak-to-peak)
-2ATX V1	24 V	240 mV
-4ATX V1	48 V	480 mV
V2	+5 V	50 mV
V3, V4	+12 V	120 mV
V5	+5 V _{standby}	50 mV

Table 3-3 Output Ripple and Noise Specification

3.4.1 Ripple and Noise Measurement

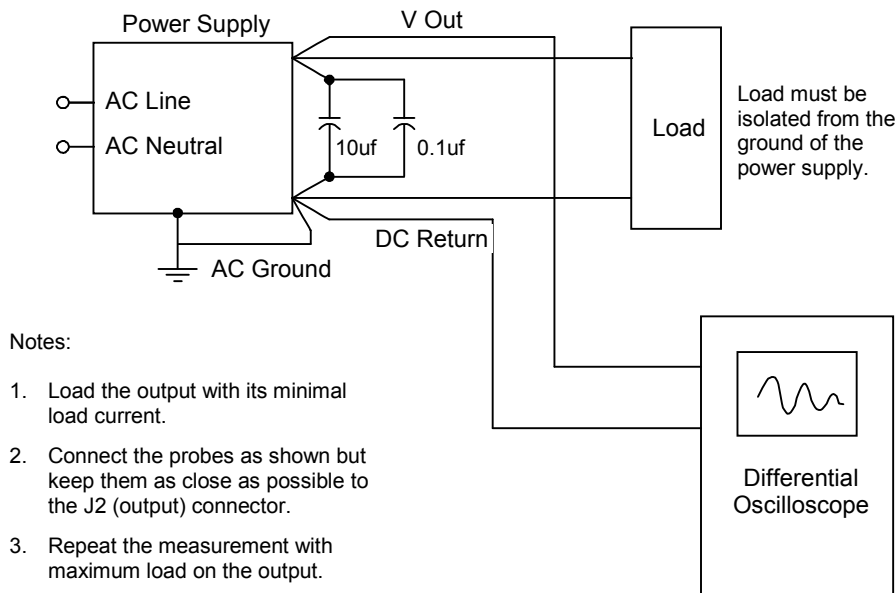

Figure 3-2 Ripple and Noise Measurement Setup

3.5 Remote Sensing

A remote sense input is provided to compensate for the normal voltage drops in the external +5V output wiring. If the +5V Sense input is left open, the 5V output will meet its load regulation specification on the J2 terminals. Connecting the +5V Sense pin to the +5V output terminal at the load will raise the +5V output voltage to help compensate for the voltage drop in the external +5V wiring. The difference between the V2 output and sense pins must be limited to 0.3-volts. This feature does not compensate for the voltage drop in the external RETURN wiring.

Figure 3-3 shows the optional remote sensing connections. Refer to Table 4-7 for the pin definition of the XL260-2ATX and -4ATX connectors.

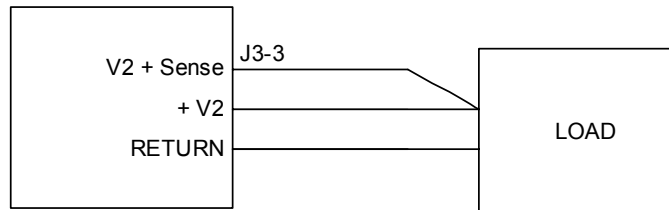

Figure 3-3 Remote 5V Sensing:

3.6 Output Protection

There are four different output protection schemes designed to protect the load and the XL260-2ATX and XL260-4ATX from component failures and extraordinary circumstances.

3.6.1 Over Temperature Protection

If the supply is operated without adequate cooling, it will sense an over-temperature condition and shut itself down. It will automatically restart after it has cooled down to a safe operating temperature.

3.6.2 Over Voltage Protection

No single component fault will cause a sustained over-voltage condition on any output. When an over-voltage condition occurs, the power supply will shut down and will not restart until AC power is turned off and back on or recycle enable (PS_ON). The XL260-2ATX and XL260-4ATX will shut down under the following over voltage conditions:

Output	Minimum	Nominal	Maximum
5 V	5.74 V	6.3 V	7.0 V
12 V	13.5 V	15.0 V	16.5 V
-2ATX 24 V	27.0 V	30.0 V	33.0 V
-4ATX 48 V	54.0 V	60.0 V	66.0 V

Table 3-4 Over Voltage Protection Thresholds

3.6.3 Over Power Protection

Excessive loads currents (including shorting an output) applied to V1 or V2 will shut down the V1 through V4 outputs. A short circuit on the V3 or V4 outputs will not cause the power supply to shut down and this output will resume normal operation when the short circuit is removed. An excessive load on the V5 output (+5Vstandby) will shut down the entire power supply. The power supply will periodically attempt to restart and should succeed after all overload conditions are removed.

The V1 output is also rated for an intermittent output of approximately 360-watts for 500-milliseconds. This excessive load must not be repeated for at least 20-seconds. Exceeding this intermittent pulse duration will cause an over-power shutdown as described in the above paragraph.

3.7 Output Rise Time

All output voltages shall rise from 10% to 90% of nominal output voltage (as specified in Table 3-1) within 0.2ms to 20ms. The rising output waveforms are monotonic from 10% to 90% under the maximum steady-state load conditions specified in Table 3-2.

3.8 Output Overshoot

The output voltages may overshoot less than 10% above the nominal voltage upon the application or removal of the input power. No opposite polarity voltage is present on any output during turn-on or turn-off.

3.9 Output Transients

The maximum output voltage transient caused by stepped load changes will not exceed the output voltage regulation limits by more than 5% of the nominal output voltage. With an AC input as specified in Section 2.1, the power supply will remain stable when subjected to the load transients described below:

Load changes between 75% and 100% on any output from 50 to 333 cycles per second

Transient load slew rate used in verification testing is 1.0-amp per microsecond

Capacitive loading per Table 3-5

3.10 Closed Loop Stability

The power supply is unconditionally stable under all line/load/transient load conditions including the capacitive loads specified in Table 3-5. The power supply shall exhibit a minimum of 45-degrees phase margin and 6 dB gain margin.

3.11 Capacitive Load

The XL260-2ATX and XL260-4ATX will startup and operate normally with external load capacitance on the outputs do not exceed those listed in Table 3-5.

Output	Capacitive Load (μf)
-2ATX 24 V	2,000 μF
-4ATX 48 V	1,000 μF
+5 V	10,000 μF
+12 V	1,000 μF
+5 V _{standby}	100 μF

Table 3-5 Capacitive Loading

3.12 Efficiency

The XL260-2ATX and XL260-4ATX are at least 85% efficient under the following loading conditions with an input voltage of 230VAC 60Hz and 10 CFM of cooling air at 25°C. Efficiency is calculated as the total DC output power divided by the RMS input power.

Output	Load Current
-2ATX 24 V	5.0 A
-4ATX 48 V	2.5 A
5V	10.0 A
12V	3.2 A
5Vsb	0.0 A

Table 3-6 Output Currents Used for Efficiency Rating

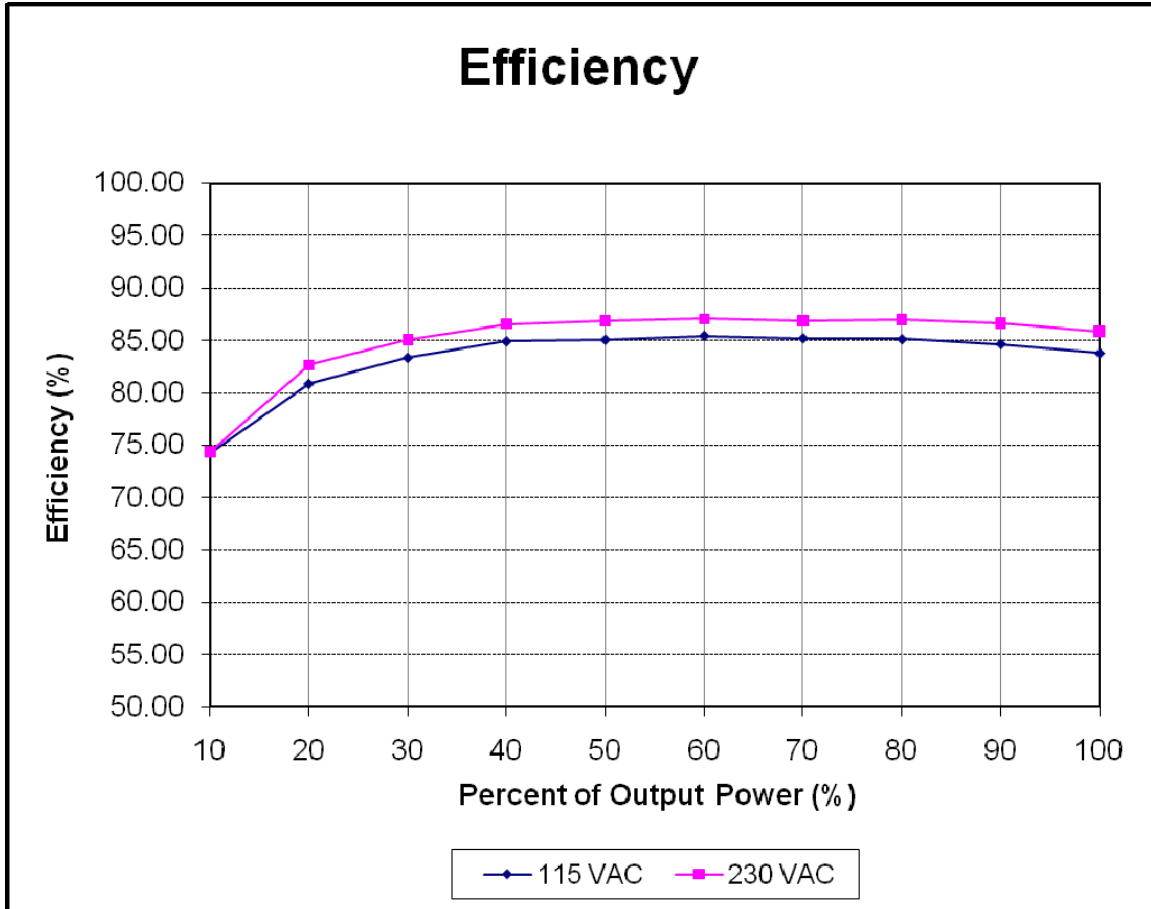

Figure 3-4 Typical Efficiency

4.

General Specifications

4.1 Environmental

The XL260-2ATX and XL260-4ATX meet or exceed the following environmental specifications:

Parameter	Conditions	Specification	Remarks
Temperature	Operating	-25°C to 50°C	See cooling requirements
	Non-Operating	-40°C to 85°C	
Relative Humidity	Operating	95% Maximum	Non-Condensing
	Non-Operating	95% Maximum	Non-Condensing
Altitude	Operating	6,561 feet MSL Max.	2,000 meters
	Non-Operating	50,000 feet MSL Max.	15,240 meters
Vibration	No damage	2.4G RMS Maximum	5-500Hz, 10-min. each axis per MIL-PRF-28800F: 3.8.4.1 (Class 3,4)
Mechanical Shock	No damage	30G half-sine, 11mS	Six shocks each axis per MIL-PRF-28800F: 4.5.5.4.1

Table 4-1 Environmental Specifications

4.2 Component Derating

The XL260-2ATX and XL260-4ATX was designed with the following component-derating guidelines at an operating ambient temperature of 50°C: semiconductor junction temperatures shall not exceed ninety (90) percent of manufacturer's rating. Inductor winding temperatures shall not exceed safety agency requirements. Electrolytic capacitor case temperatures shall not exceed 95% of rated temperature. Resistor power dissipation shall not exceed 70% of rated while other components will not be operated at more then 90% of their rated voltage or current.

4.3 Mean Time between Failures

The calculated MTBF of the power supply is equal to or greater than 690,000 hours of continuous operation at maximum output loading and worst case input line voltage with 10-CFM of forced-air cooling at 25°C. N2Power does not warrant the MTBF to be representative of any particular unit. The MTBF of the power supply is calculated with an 80% confidence level in accordance with Bellcore, SR-332, Issue 2. Actual failure rates vary from unit to unit.

4.4 Labeling/Marking

The power supply is marked and labeled with the N2Power logo and part number, model number, input and output specifications, production code, appropriate safety agency logos, CE mark, patent number, and country of origin. See Figure 4-1.

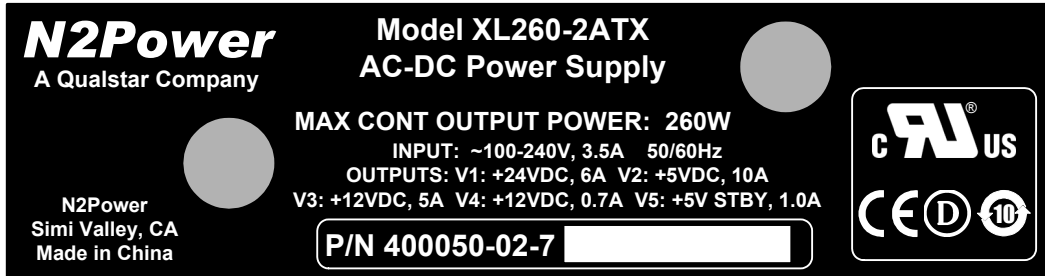

Figure 4-1 Sample XL260-2ATX Label

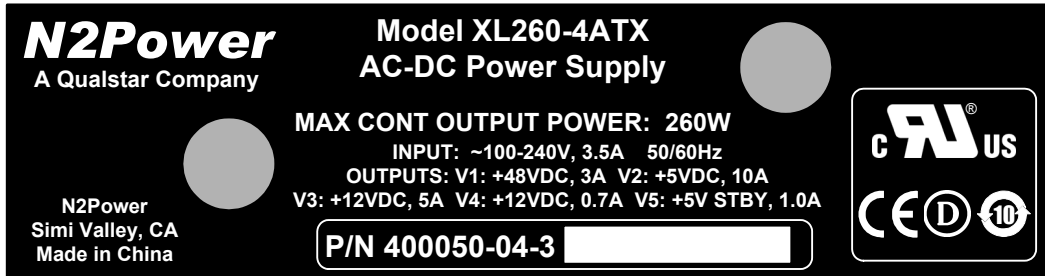

Figure 4-2 Sample XL260-4ATX Label

4.5 Mounting

The XL260-2ATX and XL260-4ATX may be mounted in any attitude but must be mounted on all four corners using M3 or 6-32 UNC hardware. Any mounting hardware (screw heads, washers, standoffs, etc.) must not exceed .282-inches (7.16-mm) in diameter to assure adequate safety agency spacing requirements with components and the printed circuit board traces.

4.6 Physical Dimensions

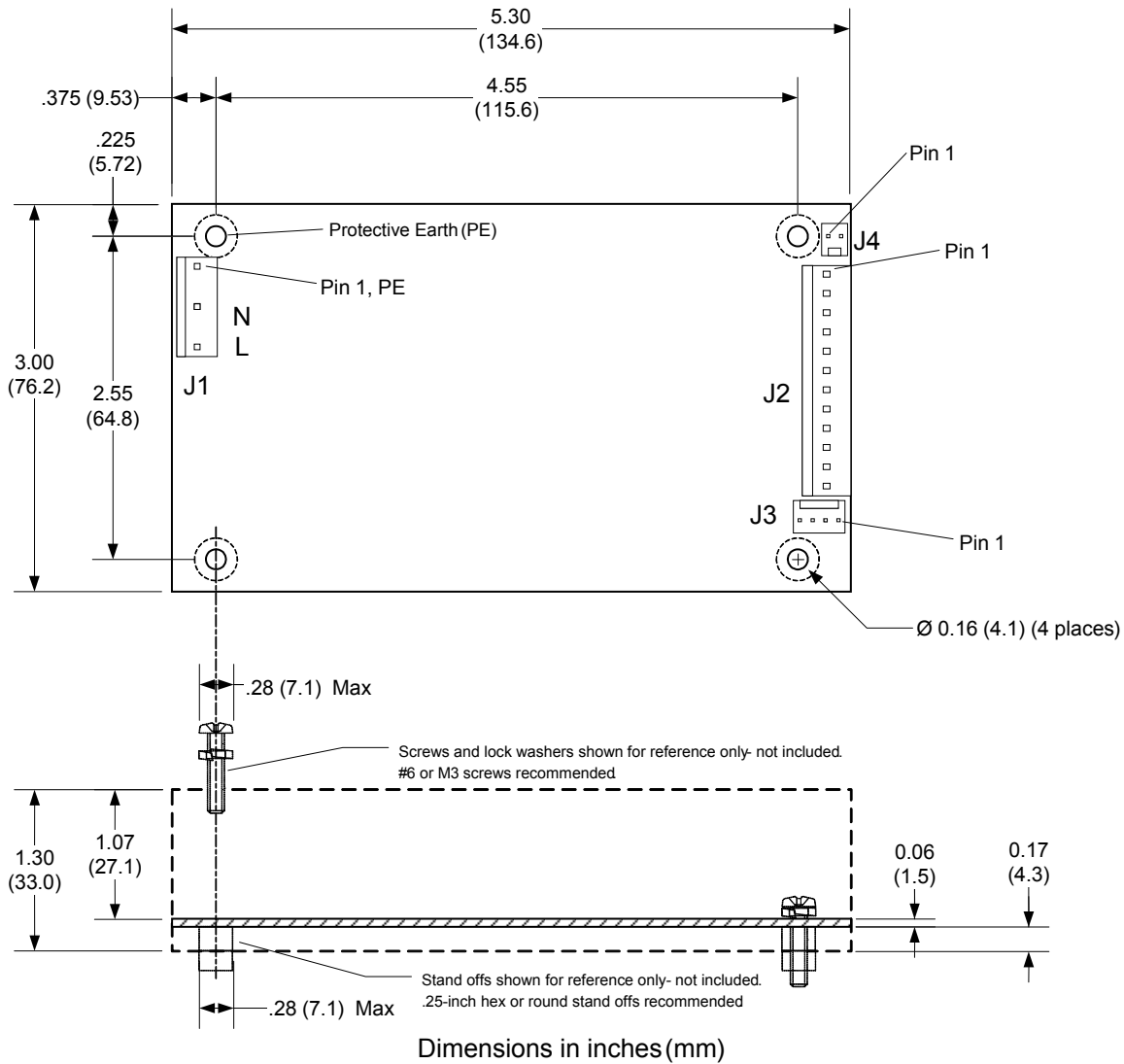

Figure 4-3 Dimensions

4.7 Weight

Weight	Units
0.91	Pounds
14.6	Ounces
0.41	Kilograms

Table 4-2 Weight of Individual Supply

4.8 Mating Connectors

The user must furnish all mating connectors. The mating connectors must meet the requirements of all applicable safety agencies (notably UL). Molex™ (Molex is a trademark of the Molex Corporation) did not change their part numbers when they took the lead out of their contacts. The Molex part numbers in this section should yield RoHS compliant contacts. The largest wire size accepted by each contact should be used for all power connections to help dissipate the heat generated by the resistive connections.

Note that the female contacts that mate to the power supply are only rated for 25-30 mating cycles. Excessive mating cycles will cause a dramatic increase in terminal resistance resulting in local heating that will cause eventual failure of the mating terminal and possibly the header on the power supply.

CAUTION

The pin-1 location differs amongst connector manufacturers. Sometimes pin-1 differs between the header (on the power supply) and the mating housing from the same manufacturer. Disregard the manufacturer's pin-1 location and follow only the pin-1 locations in Figure 4.2

4.8.1 AC Input Mating Connector J1

The AC input connector is a 5-pin Molex KK-156 style header with 0.156" centers. The pins 2 and 4 are omitted to provide adequate insulation spacing. The Molex part numbers for the mating housing and crimp-style snap-in terminals are listed below. There may be equivalent connectors available from other manufacturers.

J1	Molex P/Ns
Connector Circuits (pins)	3 of 5
Mating Housing	09-50-8051
Crimp Terminal (tin)	08-50-0113
Rated Contact Current	6.3 A @ AWG 20
Rated Wire Size	AWG 18 or 20

Table 4-3 J1 Mating Connector

4.8.2 DC Output Connector J2

The DC output connector is a Molex KK-156 style header with 0.156” centers. The Molex part numbers for the mating housing and crimp-style snap-in terminals are listed below. There may be equivalent connectors available from other manufacturers.

J2	Molex P/Ns
Connector Circuits (pins)	12
Mating Housing	09-50-8121
Crimp Terminal (tin)	08-50-0113
Rated Contact Current	7.0 A @ AWG 18
Rated Wire Size	AWG 18 or 20

Table 4-4 J2 Mating Connector

4.8.3 Remote Sense / Enable J3

The Remote Sense/Enable connector is a Molex KK-100 style header with 0.100” centers. The Molex part numbers for the mating housing and crimp-style snap-in terminals are listed below. There may be equivalent connectors available from other manufacturers.

J3	Molex P/Ns
Connector Circuits (pins)	4
Mating Housing	22-01-3047
Crimp terminal (tin)	08-50-0114
Rated Contact Current	2.5 A
Rated Wire Size	AWG 22 thru 30

Table 4-5 J3 Mating Connector

4.8.4 Fan Connector J4

The Fan connector is a Molex KK-100 style header with 0.100” centers. The Molex part numbers for the mating housing and crimp-style snap-in terminals are listed below. There may be equivalent connectors available from other manufacturers.

J4	Molex P/Ns
Connector Circuits (pins)	2
Mating Housing	22-01-3027
Crimp terminal (tin)	08-50-0114
Rated Contact Current	2.5 A
Rated Wire Size	AWG 22 thru 30

Table 4-6 J4 Mating Connector

4.9 Output Grounding

The DC RETURN signal may be connected to the power supply chassis ground (safety ground) at the plated through mounting hole nearest the J1 input connector.

4.10 Signal Pin Definitions

- Identical signal names are connected together on all connectors
- The safety ground connection is provided by the mounting screw near J1
- Refer to Figure 4-3 for connector and pin-1 locations

Pin	Signal
J1-1	Protective Earth (PE)
J1-3	AC Neutral Input
J1-5	AC Line Input
J2-1	V3 (+12 V)
J2-2	V2 (+5 V)
J2-3	V2 (+5 V)
J2-4	V2 (+5 V)
J2-5	DC RETURN (0V)
J2-6	DC RETURN (0V)
J2-7	DC RETURN (0V)
J2-8	DC RETURN (0V)
J2-9	DC RETURN (0V)
J2-10	V1 (+24V/+48V)
J2-11	V1 (+24V/+48V)
J2-12	V5 (+5 V _{standby})
J3-1	PS_ON (Low True)
J3-2	PG
J3-3	5V SEN
J3-4	DC RETURN (0V)
J4-1	+FAN (12V)
J4-2	-FAN (12V)

Table 4-7 I/O Pin Definitions

5.

Timing and Control

5.1 Power Supply Timing

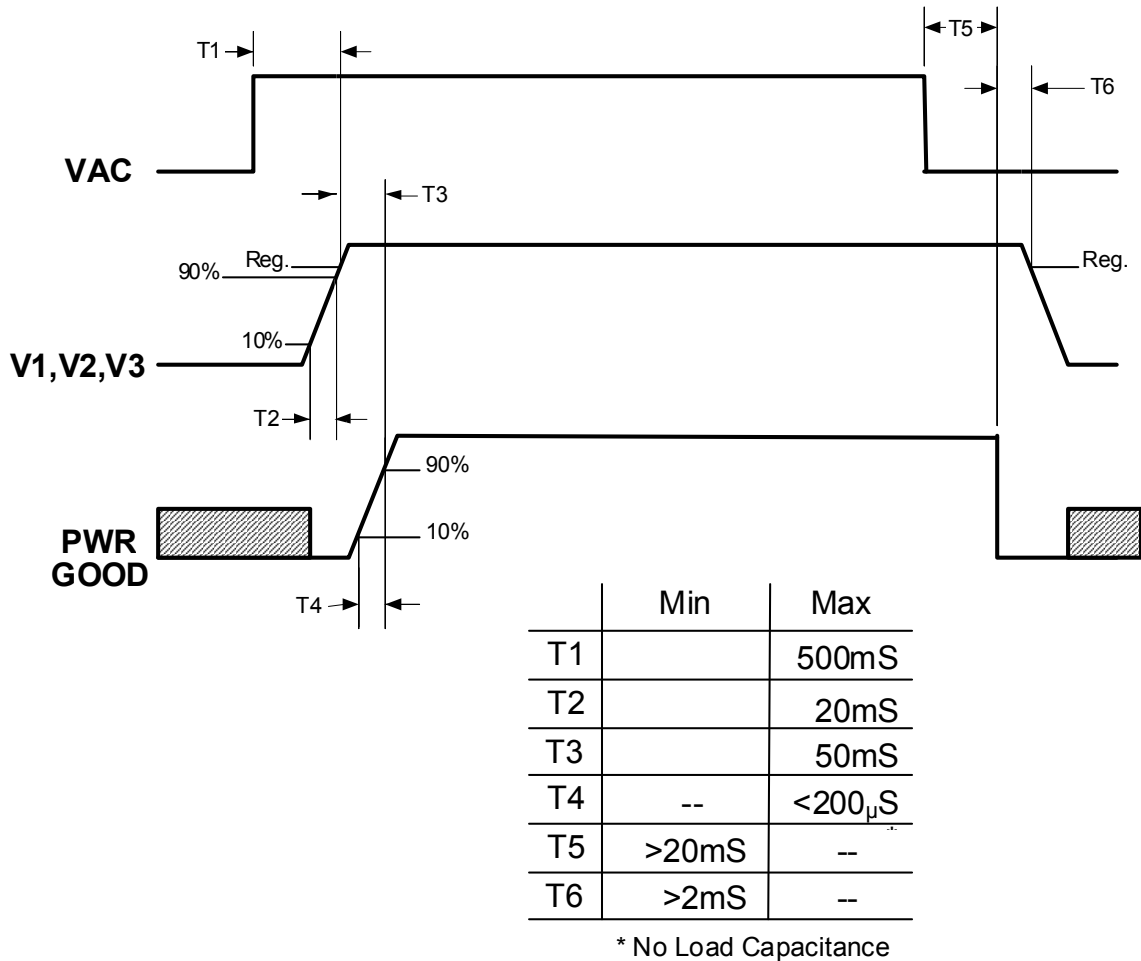

Figure 5-1 XL260-2ATX and XL260-4ATX Timing Diagram

5.2 Power Good Signal

The Power Good Signal provides a high logic level to indicate that sufficient time has expired for the DC outputs to be within their regulation limits and that sufficient mains energy is stored by the power supply to ensure continuous power operation within specification for the duration of the hold-up time. When the AC mains power is removed for a period longer than 20ms, the Power Good Signal transitions to a low logic level. The PG signal is driven by an open collector TL331 comparator with a 2K pull up resistor connected to the internal +5V SB.

5.3 PS_ON Input

The V1 through V3 outputs are enabled whenever the PS_ON/ input (J3 pin-1) is grounded to DC RETURN (J2 pin-5 thru 9 or J3-4). Opening the PS_ON/ input will disable the three outputs and cause the Power Good output to go false. The PS_ON/ input has an internal 2K-ohm pull-up resistor connected to +5 V_{standby}.

The special order S91 option changes the logic sense of the PS_ON input from low-true with a pull-up resistor to high-true with a 10 K-ohm pull-down resistor. Consult sales for details.

5.4 Hold-Up Time

The power supply will maintain output regulation (per Table 3-1) despite a momentary (lasting up to 20-milliseconds) and complete loss of input power when operating at any rated input voltage (per Table 1-1) at any rated load condition (per Table 3-2).

6.

Ordering Information

The following table provides the N2Power part number that should appear on your purchase order and will appear on any N2Power correspondence:

Model Number	N2Power Part Number
XL260-2ATX	400050-02-7
XL260-4ATX	400050-04-3

Table 6-1 Ordering Information

The XL260-2ATX and XL260-4ATX are RoHS compliant.

For warranty information refer to www.n2power.com

Direct all questions, orders or requests for quotation as follows:

N2Power Order Desk:	orders@n2power.com 805-583-7744 x112
Fax (Attention N2Power):	805-583-7749
Sales:	sales@n2power.com 805-583-7744 x122
Technical Support	techsupport@n2power.com 805-583-7744 x119
Street Address:	N2Power a Qualstar Company 3990-B Heritage Oak Court Simi Valley CA 93063