



Product Specification

XS285ATX

**285-watt AC to DC
Power Supply Subsystem**

703933 Rev. A4

Notices

N2Power is a wholly owned subsidiary of Qualstar Corporation.

N2Power and the *N2Power* logo are registered trademarks of Qualstar Corporation.

Copyright© 2006, 2009 by Qualstar Corporation — All Rights Reserved

Information contained in this document is copyrighted by Qualstar Corporation and is intended for use by customers and prospective customers to evaluate and integrate our power supplies. Customers and prospective customers may reproduce this document as needed for these purposes. Reproduction in whole or in part for any other purpose or by any other party is prohibited without prior written permission from Qualstar Corporation.

Every effort has been made to keep the information contained in this document current and accurate as of the date of publication or revision. However, no guarantee is given or implied that the document is error-free or that it is accurate with regard to any specification.

N2Power reserves the right to modify the design or specification without notice. This specification may not be construed as a contractual obligation except as specifically agreed to by *N2Power* in writing at the time of order.

For information about this product specification, please write or call *N2Power* at:

N2Power

A Qualstar Company
3990-B Heritage Oak Court
Simi Valley CA 93063

FAX: (805) 583-7749
Phone: (805) 583-7744

E-Mail: sales@n2power.com
www.n2power.com

Table of Contents

1.	Introduction.....	1-1
1.1	Introduction.....	1-1
2.	AC Input.....	2-1
2.1	Input Line Requirements	2-1
2.2	Input Over Current Protection	2-1
2.3	Inrush Current Limiting	2-1
2.4	Low Input Voltage	2-1
2.5	Leakage Current.....	2-1
3.	DC Outputs.....	3-1
3.1	Output Voltage Regulation	3-1
3.2	No Load Operation.....	3-1
3.3	Output Current/Power	3-1
3.4	Efficiency	3-3
3.5	Cooling.....	3-4
3.6	Output Ripple/Noise	3-4
3.7	Power Supply Protection	3-5
3.8	Output Rise Time.....	3-6
3.9	Overshoot At Turn On/Turn Off	3-6
3.10	Output Transients	3-6
3.11	Closed Loop Stability.....	3-7
3.12	Capacitive Loading	3-7
4.	General Specifications	4-1
4.1	Environmental	4-1
4.2	Mean Time Between Failures.....	4-1
4.3	Component Stress.....	4-1
4.4	Labeling/Marking	4-1
4.5	Output Wiring Harness.....	4-2
4.6	Weight	4-2
4.7	Physical Dimensions.....	4-3
5.	Timing and Control.....	5-1
5.1	Power Supply Timing	5-1
5.2	Power Good Signal.....	5-1
5.3	Voltage Hold-Up Time	5-2
5.4	Output Rise Time.....	5-2
5.5	Overshoot at Turn On/Turn Off.....	5-2
6.	Ordering Information.....	6-1

1.1 Introduction

This specification defines characteristics of an single-phase (3 wire) universal input, power factor corrected, multiple-output, 285-watt switch mode power supply subsystem. This product was designed for the gaming industry where high efficiency and reliability are of paramount importance. It is intended to power a computer, lighting and a currency reader/receiver. The XL285ATX utilizes the industry standard ATX form-factor housing with an integral fan, AC power rocker switch and standard IEC power receptacle.

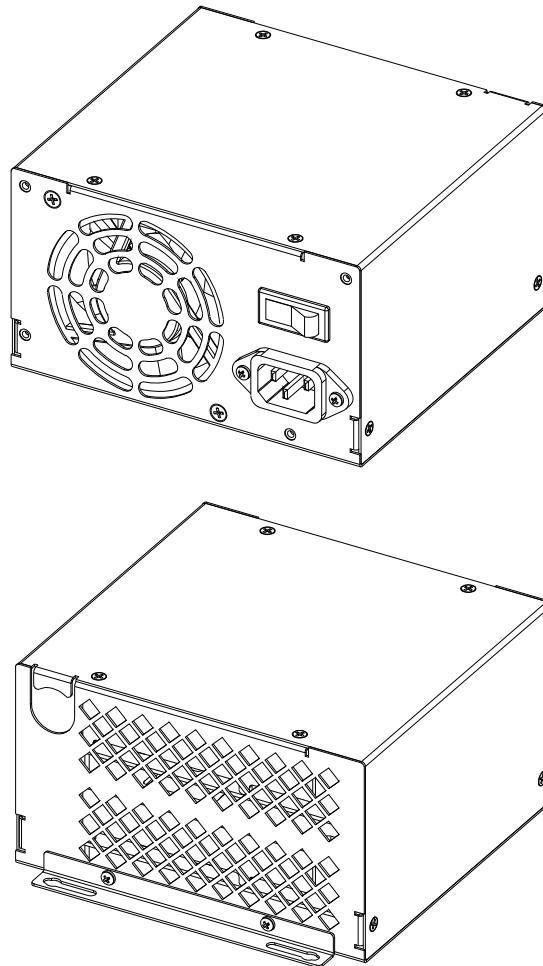

Table 1-1 The XS285ATX shown without the output harness (exits lower view, U/L corner)

2.1 Input Line Requirements

The following table defines the voltage and frequency requirements for the AC line inputs to the XS285ATX power supply that is capable of supplying full rated power in continuous operation throughout the specified ranges of voltages and frequencies. The power supply will automatically recover from AC power loss and is capable of starting under maximum load at the minimum AC input voltage described below.

Parameter	Minimum	Rated	Maximum
RMS Input Voltage	90 VAC	100–240 VAC	264 VAC
RMS Input Current	–	–	4.0 A @ 100 V 1.8 A @ 240 V
Input Frequency	47 Hz	50–60 Hz	63 Hz

Table 2-1 XS285ATX AC Input Parameters

2.2 Input Over Current Protection

The XS285ATX series incorporates primary AC line fuses for input over current protection to prevent damage to the power supply and meet product safety requirements.

2.3 Inrush Current Limiting

The cold start inrush current is limited to 66 A peak at 115 VAC. Repetitive ON/OFF cycling of the AC input voltage shall not damage the power supply or cause the input fuse to fail.

2.4 Low Input Voltage

The application of an input voltage below the minimums specified in Table 2-1 shall not damage the XS285ATX.

2.5 Leakage Current

The leakage current from AC line or AC Neutral inputs to Earth Ground at 240 VAC, 50Hz is less than 1500 microamps.

3.

DC Outputs

3.1 Output Voltage Regulation

The DC output voltages shall remain within the minimum and maximum limits of Table 3-1 when measured at the power supply connector under all specified line and environmental conditions contained herein. The regulation accuracy is measured with load currents between the minimum and maximum load currents listed in Table 3-2 and does not account for voltage drops in the output wiring harness.

Output	Voltage	Regulation	Minimum (VDC)	Nominal (VDC)	Maximum (VDC)
V1	+3.3 V	±2%	3.234	3.300	3.366
V2	+5 V	±4%	4.848	5.050	5.252
V3	+12 V	±5%	11.400	12.000	12.600
V4	-12 V	±5%	-11.400	-12.000	-12.600
V5	+24 V	±3%	23.280	24.000	24.720

Table 3-1 XS285ATX Output Voltage Specifications

3.2 No Load Operation

The V1 through V4 outputs will operate with reduced output voltage regulation of +/- 10% when unloaded. This no load condition will not damage the supply or cause a hazardous condition, however the Power Good signal may not go true with less than a 5-watt load on V1-V4. The V5 output requires a minimum load of 0.1A. The power supply will remain stable and operate normally after application of loads.

CAUTION

Remove AC power prior to connecting or disconnecting DC loads.

3.3 Output Current/Power

The maximum available output power is always a function of the cooling airflow and temperature. An adequate supply of cooling air that is below 51°C must be available. No output will exceed 240VA under any of overload or short circuit condition including single component fault conditions as described by IEC 60950.

3.3.1 Loading Envelope

The V5 (+24V) output is rated at 5.2A total output current independently of the other output voltages.

The following cross-loading diagram indicates the maximum continuous power levels available from the V1-V4 outputs. The diagram only deals with the V1 (+3.3V), V2 (+5V) and V3 (+12V) outputs because they are inter-related. Except for a combined maximum power dissipation limit of 160-watts for V1-V4, the V4 (-12V) output is independent from the V1-V3 and V5 outputs.

The eight segments of the load limit polygon are described below:

- a) In order to keep the +12V output within its regulation specification with less than 0.5 amps load, the combined V1 and +5V output current must be limited as shown by this segment. The combined V1 and +5V output can be raised to the full 100-watt limit if a +12V output voltage regulation of 6.5% (normally 5%) is acceptable.
- b) The top horizontal line indicates a combined limit of 100-watts for the V1 and +5V.
- c) The total output of the V1, +5V and +12V outputs is limited to 160-watts.
- d) The +12V output is limited to 6.0 amps.
- e) When the combined load from the V1 and +5V outputs is below this line, the +5V output could experience an additional voltage regulation error of 1.5%.
- f) A minimum of 5-watts is required from the +12V output to keep the unloaded +5V output within its voltage regulation specification.
- g) A combined minimum of 5-watts from the V1, +5V and +12V outputs is required for a Power Good indication (Power Good signal high, PS_OK signal low).
- h) A combined minimum of 5-watts is required from the V1 and +5V outputs to keep the unloaded +12V output within its voltage regulation specification.

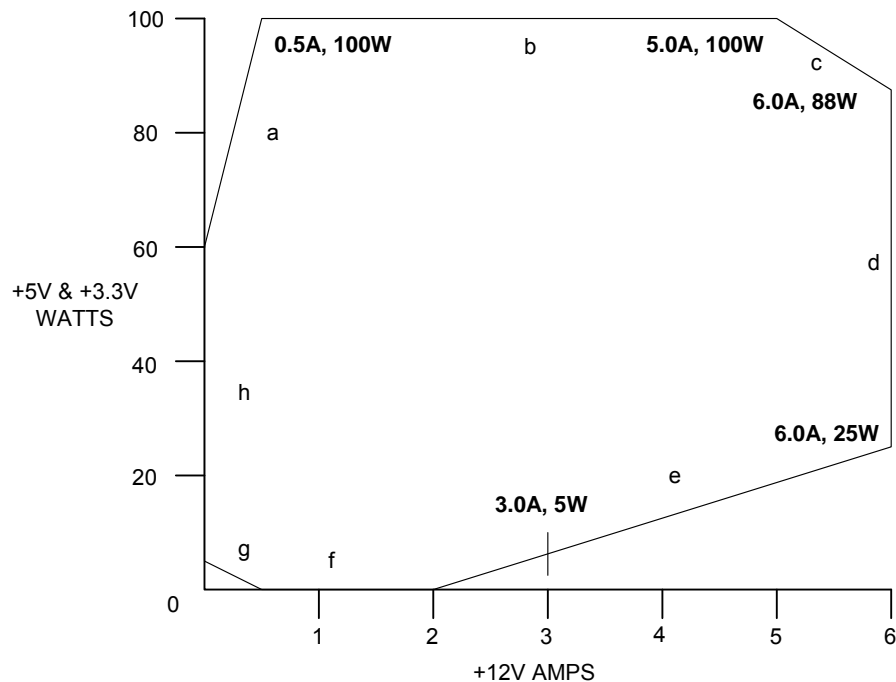

Figure 3-1 XS285ATX Loading Envelope for V1, V2 and V3

Output	Rated Voltage	Minimum Load	Maximum Load
V1	+3.3 V	0.0 A	15.0 A
V2	+5 V	1.0 A	20.0 A
V3	+12 V	0.0 A	6.0 A
V4	-12 V	0.0 A	1.0 A
V5	+24 V	0.1 A	5.2 A

Table 3-2 XS285ATX Min/Max Load Currents

3.4 Efficiency

The power supply efficiency varies with the output load and the line voltage. The V1-V4 outputs will meet efficiencies of at least 83% under defined loading conditions specified in Table 3-3 with a line voltage of 230VAC at 25°C.

Output	Voltage	Current
V1	+3.3 V	3.8 A
V2	+5 V	8.0 A
V3	+12 V	6.0 A
V4	-12 V	0.3 A
V5	+24V	5.2 A

Table 3-3 Output Loads Used to Rate Efficiency

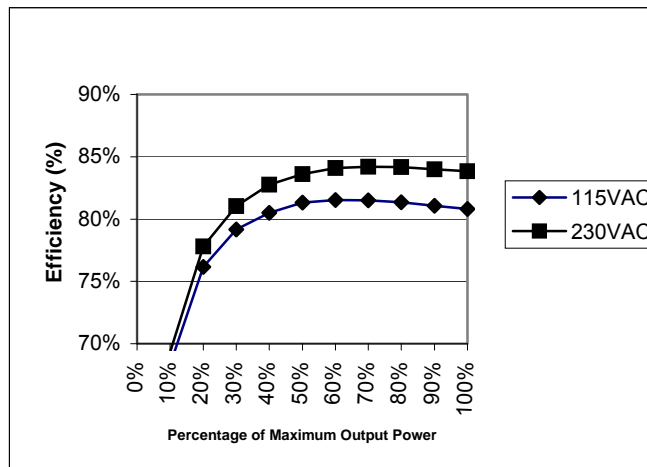

Table 3-4 Combined Efficiency of V1-V5

3.5 Cooling

The fan outlet and all vent holes must remain unrestricted to airflow and the ambient air temperature must not exceed 50°C when fully loaded.

3.5.1 Output Power Derating at Elevated Temperatures

The XS285ATX can be operated with cooling air temperatures above 50°C by linearly derating the total maximum output power (or current) by 2.5%/°C from 50°C to 70°C (see Figure 3-2).

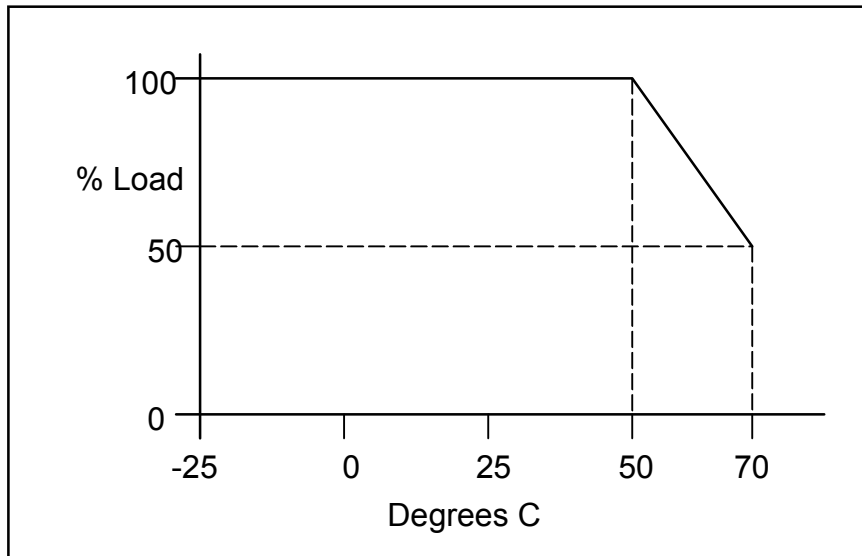

Figure 3-2 XS285ATX Output Power vs. Ambient Temperature Envelope

3.5.2 Over-temperature Shutdown

The XS285ATX is equipped with internal temperature sensors. Failure to provide adequate cooling airflow below the maximum operating temperature will result in the V5 output and/or V1-V4 outputs shutting down. The AC input power must be cycled off and back on to restore the output power after an over-temperature shutdown.

3.6 Output Ripple/Noise

Output ripple voltage and noise are defined as periodic or random signals over a frequency band of 10 Hz to 20 MHz. Measurements are to be made with an oscilloscope with at least 20 MHz bandwidth. Outputs should be bypassed at the load with a 0.1 μ F ceramic disk capacitor and a 10 μ F tantalum capacitor to simulate system loading.

The ripple voltage of the outputs is measured at supply outputs internal to the enclosure. Ripple and noise shall not exceed the limits specified in Table 3-5 under

any condition of line voltage and frequency specified in Section 2.1 and DC loading specified in Section 3.3.1. The output harness can add resistance and inductance that could increase the ripple and noise at the load.

Output	Voltage	Maximum Ripple+Noise (peak-to-peak)
V1	+3.3/+2.5/0 V	50 mV
V2	+5 V	50 mV
V3	+12 V	120 mV
V4	-12 V	120 mV
V5	+24 V	240 mV

Table 3-5 Ripple/Noise Limits before Output Harness

3.7 Power Supply Protection

There are several different protection circuits designed to protect the load and the XS285ATX from component failures and extraordinary circumstances.

3.7.1 Over Temperature Protection

If the XS285ATX is operated without adequate cooling, it will sense an over-temperature condition and shut down. It will restart after it has cooled down to below its maximum operating temperature. The V5 (+24V) output is separately protected.

3.7.2 Over-Voltage Protection

No single fault is able to cause a sustained over voltage condition on any output. When an over-voltage condition occurs, the power supply will shut down and will not restart until AC power is turned off and back on. The XS285ATX will shut down under the following over voltage conditions:

Output	Minimum	Nominal	Maximum
3.3 V	3.76 V	4.2 V	4.8 V
5 V	5.74 V	6.3 V	7.0 V
12 V	13.5 V	15.0 V	16.5 V
24 V	27.0 V	30.0 V	33.0 V

Table 3-6 Over Voltage Protection Limits

3.7.3 Over Current Protection

Overload currents applied to any output will cause the output to shut down before reaching or exceeding the safety energy level (SELV) of 240VA. This feature is tested with an ever-increasing load at a rate of 10 A/second starting at maximum load.

Pulsating loads of 150% of the rated output can be sustained for 10-milliseconds provided the duty cycle does not exceed 10%. The total RMS power must still be limited to 160-watts.

3.7.4 Short Circuit Protection

A short circuit is defined as an impedance of less than 0.1 ohms placed between DC RETURN and any output. A short circuit will cause no damage to the power supply and will cause it to shutdown. The power supply will periodically attempt to restart until the short circuit condition is removed. After successfully restarting, the power supply will operate normally.

A short circuit on the 12V_{aux}/-12V output will not cause the power supply to shut down and the output will resume normal operation when the short circuit is removed.

3.8 Output Rise Time

All output voltages shall rise from 10% to 90% of nominal output voltage (as specified in Table 3-1) within 0.2ms to 20ms. The output voltage waveforms are monotonic ramps from 10% to 90% of final set point within the regulation band under any loading conditions specified in Table 3-2.

3.9 Overshoot At Turn On/Turn Off

The output voltage overshoot upon the application or removal of the input mains voltage is less than 10% above the nominal voltage. No opposite polarity voltage is present on any output during turn on or turn off.

3.10 Output Transients

The maximum output voltage transient caused by step load changes will not exceed the output voltage regulation limits by more than 5%. With an AC input as specified in Section 2.1, the power supply will remain stable when subjected to the load transients described below:

- Load changes between 75% and 100% on any output
- Load changing repetition of 50 to 333 cycles per second
- Transient load slew rate = 1.0 A/microsecond
- Capacitive loading per Table 3-7

3.11 Closed Loop Stability

The power supply is unconditionally stable under all line/load/transient load conditions including the capacitive loads specified in Table 3-7. The power supply shall exhibit a minimum of 45-degrees phase margin and 6 dB of gain margin.

3.12 Capacitive Loading

The XS285ATX will startup and operate normally with load capacitances simultaneously present on the all outputs not exceeding those listed in Table 3-7.

Output	Voltage	Capacitance
V1	+3.3 V	6,000 μ F
V2	+5 V	10,000 μ F
V3	+12 V	1,000 μ F
V4	-12 V _{aux}	350 μ F
V5	+24 V	2,000 μ F

Table 3-7 XS285ATX Maximum Capacitive Loading

4.

General Specifications

4.1 Environmental

The XS285ATX meets or exceeds the following environmental specifications:

Parameter	Conditions	Specification	Remarks
Temperature	Operating	-25°C to 50°C	See cooling requirements
	Non-Operating	-40°C to 85°C	
Relative Humidity	Operating	85% Maximum	Non-Condensing
	Non-Operating	95% Maximum	Non-Condensing
Altitude	Operating	10,000 feet MSL Max.	3048 meters
	Non-Operating	50,000 feet MSL Max.	15,240 meters
Vibration	No damage	2.4G RMS Maximum	5-500Hz, 10-min. each axis
Mechanical Shock	No damage	15G half-sine, 11mS	Six shocks each axis

Table 4-1 Environmental Specifications

4.2 Mean Time Between Failures

The calculated MTBF of the power supply is equal to or greater than 100,000 hours of continuous operation at maximum output loading and worst-case input line voltage at 25°C. N2Power does not warrant the MTBF to be representative of any particular unit. The MTBF of the power supply is calculated with an 80% confidence level in accordance with Bellcore, TR-332, Issue 6. Actual failure rates vary from unit to unit.

4.3 Component Stress

The XS285ATX was designed with the following component-derating guidelines at an operating ambient temperature of 50°C: semiconductor junction temperatures shall not exceed ninety (90) percent of manufacturer's rating. Inductor winding temperatures shall not exceed safety agency requirements. Electrolytic capacitor case temperatures shall not exceed 95% of rated temperature. Resistor power dissipation shall not exceed 70% of rated while other components will not be operated at more than 90% of their rated voltage or current.

4.4 Labeling/Marking

The XL285ATX is marked and labeled with the N2Power logo model number, part number, input and output specifications and country of origin. A typical label is pictured below.

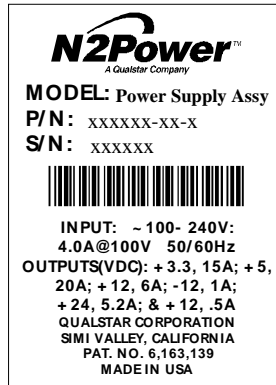

Figure 4-1 Sample XS285ATX Label

4.5 Output Wiring Harness

Custom wiring harnesses are available for the XS285ATX and detailed drawings of them are available by contacting sales@n2power.com. Each output connector also carries the power return lines (power ground). The standard wiring harness (harness-01) has 10 output connectors as follows.

Quantity	Designated	Number of Pins	Output Voltages	Remarks
1	P5	20	+3.3V, +5V, +12V, -12V	Standard ATX Motherboard connector and pinout
1	P6	4	+12V	Molex Minifit Jr. P/N 39-01-3042
5	P10-P14	4	+5V, +12V	Standard Disk Drive connector and pinout
3	P7-P9	2	+12V	Molex P/N 03-06-1023

Table 4-2 Output Harness-01 Breakout (P/N 510248-01-6)

4.6 Weight

Net Weight	
Pounds	3.22
Kilograms	1.46

Table 4-3 XS285ATX Weight

4.7 Physical Dimensions

The XS285ATX may be mounted in any attitude. 3D CAD models are available by contacting sales@n2power.com.

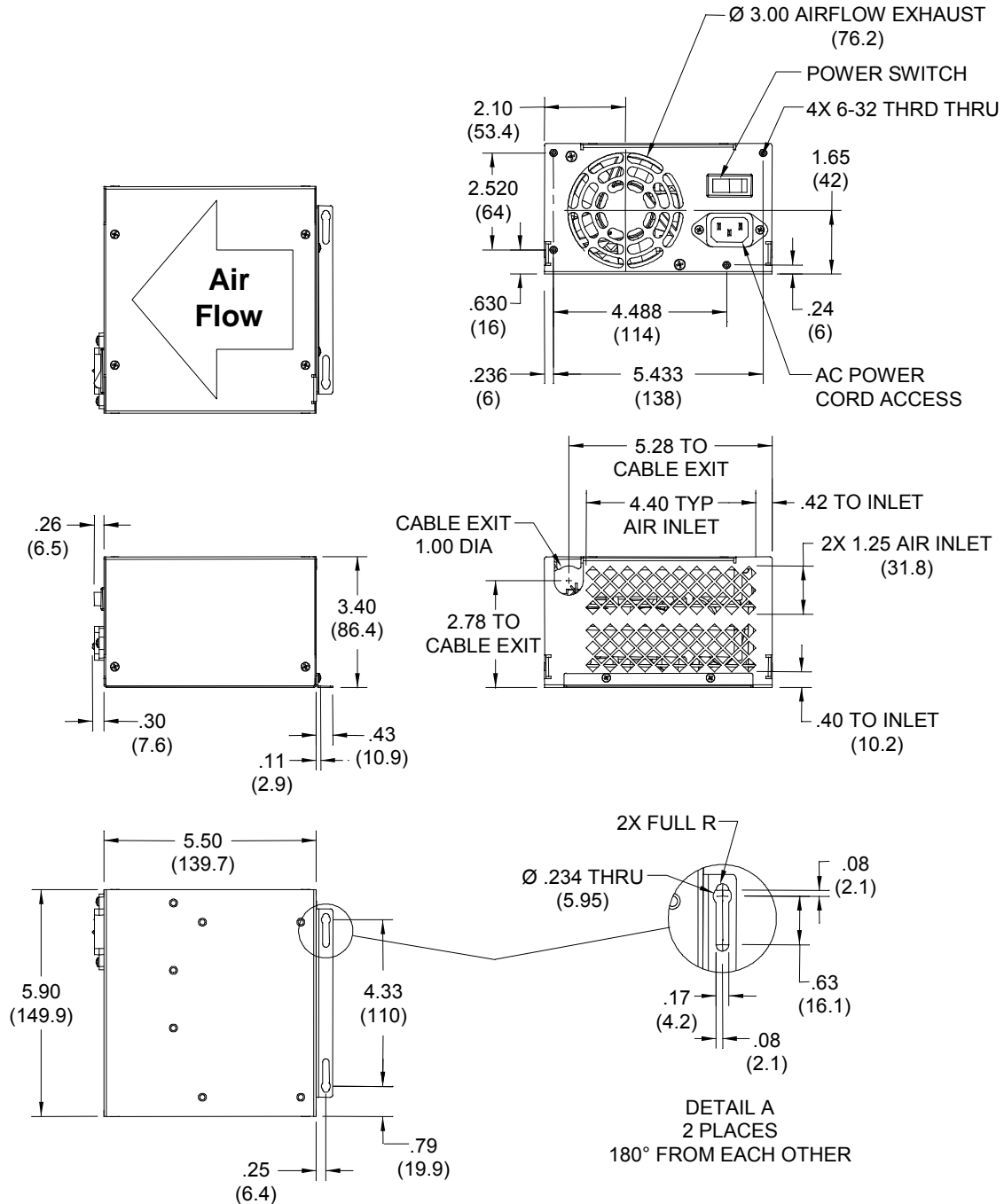

Figure 4-2 XS285ATX Dimensions

5.

Timing and Control

5.1 Power Supply Timing

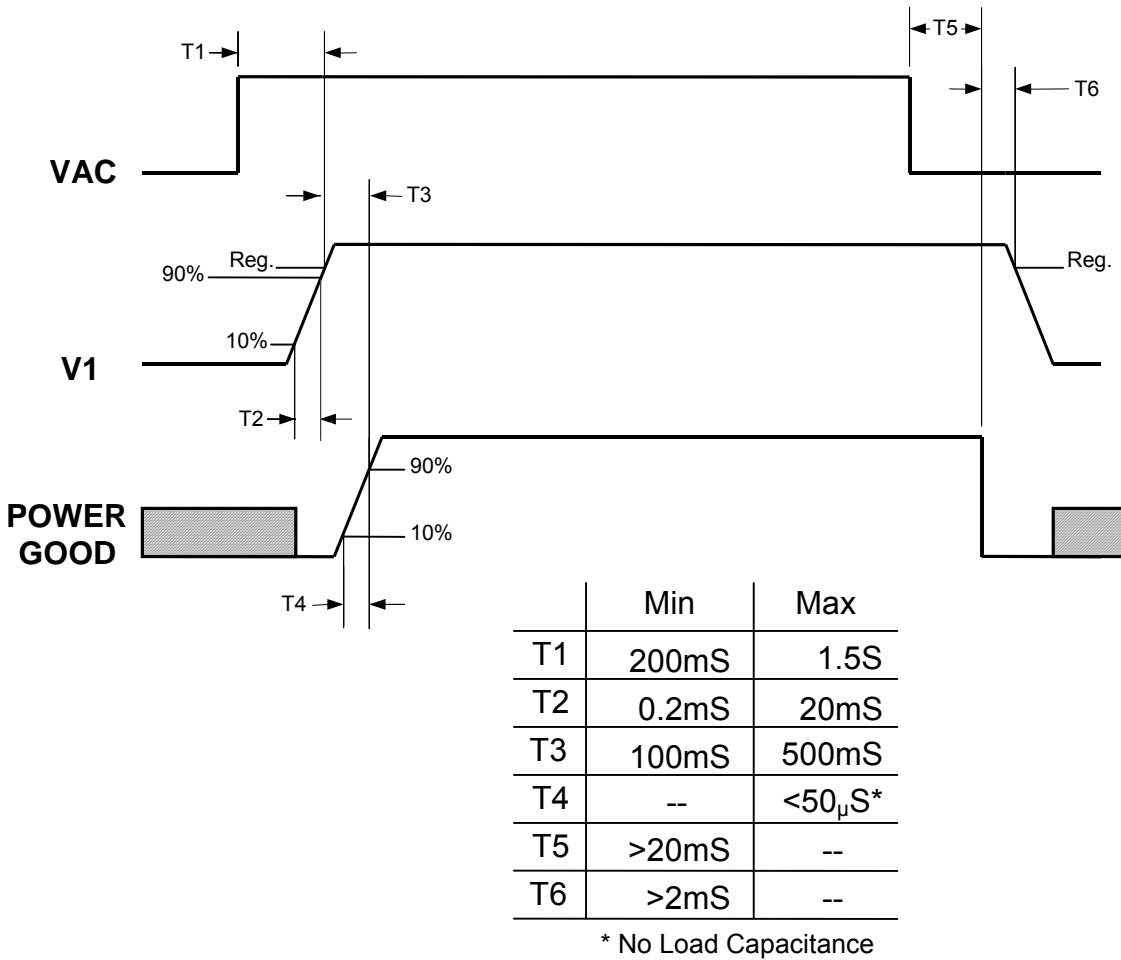

Figure 5-1 XS285ATX Timing Diagram

5.2 Power Good Signal

The Power Good Signal provides a high logic level to indicate that sufficient time has expired for the DC outputs to be within their regulation limits and that sufficient mains energy is stored by the power supply to ensure continuous power operation within specification for the duration of the hold-up time. When the AC mains power is removed for a period longer than 20ms, the Power Good Signal transitions to a low logic level. The power Good signal is driven low by an open-collector NPN transistor with the ability to sink 4 mA at less than 0.4V out and is pulled-up to 4.5V with a 4.7K ohm resistor.

5.3 Voltage Hold-Up Time

The power supply will maintain output regulation per Table 3-1 despite a loss of input power at 100VAC/50Hz and 230VAC/50Hz at maximum continuous output load for a minimum of 22-milliseconds.

5.4 Output Rise Time

All output voltages shall rise monotonically (always positive slope) from 10% to 90% of their nominal output voltage (as specified in Table 3-1) within 0.2ms to 20ms under any loading conditions specified in within this document.

5.5 Overshoot at Turn On/Turn Off

The output voltage overshoot upon the application or removal of the input mains voltage is less than 10% above the nominal voltage. No opposite polarity voltage is present on any output during turn on or turn off.

6.

Ordering Information

The model number (XS285ATX) is followed by a dash and a letter defining the output harness (-01 is the standard harness). The following table provides the N2Power part numbers that should appear on your purchase order and will appear on any N2Power correspondence:

Model Number	N2Power Part Number
XS285ATX-01	400027-01-7

Table 6-1 XS285ATX Part Numbers

Direct all questions, orders or requests for quotation as follows:

N2Power Order Desk:	orders@n2power.com 805-583-7744 x112
Fax (Attention N2Power):	805-583-7749
Sales Manager:	sales@n2power.com 805-583-7744 x122
Technical Support	techsupport@n2power.com 805-583-7744 x119
Street Address:	N2Power a Qualstar Company 3990-B Heritage Oak Court Simi Valley CA 93063